



# EXPLOSION-PROOF AIR CONDITIONERS

## PACX Explosion Proof Packaged AirConditioners

### How to Order

- 1.- Determine the preferred direction of air discharge and return, downflow or horizontal.
- 2.- Determine required cooling capacity in nominal tons (12,000 BTUH per ton).For computer assisted load calculation contact factory and request Technical Support Bulletin REHV1FRM.
- 3.- Determine required voltage configuration. For 50 Hertz models contact factory.
- 4.- Determine hazard classification per National Electric Code (NEC). For example Class I, Group D, Division 2..
- 4.- Select the model number following the order code below.
- 5.- Scan the "Options and Accessories" listing below and select the desired items. Order by adding and slash and the order code of the selection accessory or option. For example: PACX - H - 050 - 1 - B - ID2 / EH (4) / FDI
- 4.- For technical or pricing information contact your representative or Sales Engineering at (800) 654-3857.

### Model Number Description

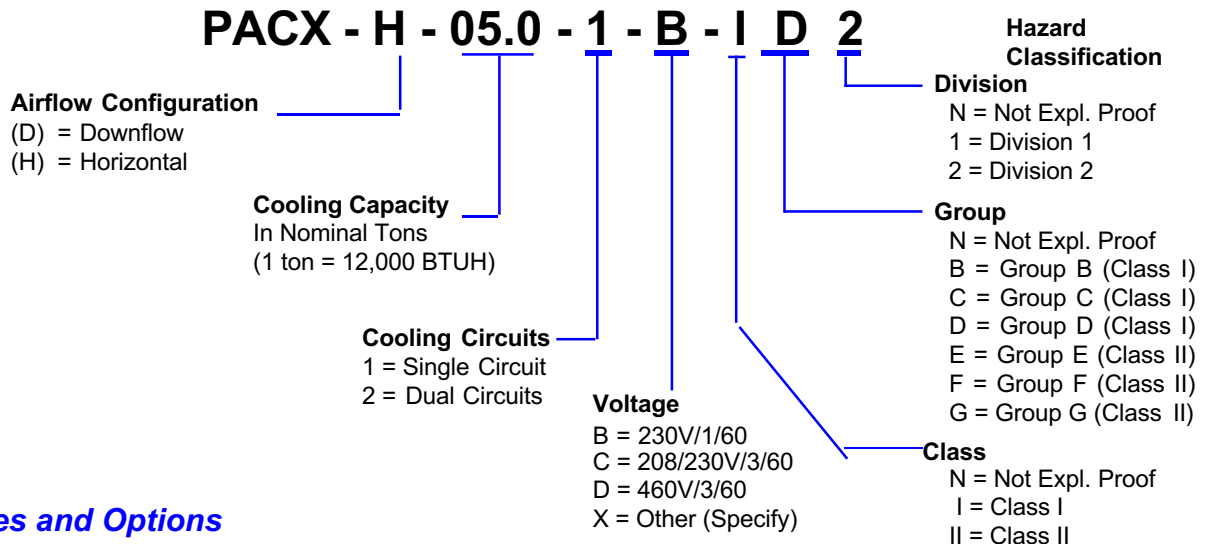

### Accessories and Options

Model	Description
TCXP-C-1101	Thermostat, Cool Only, Class I and II, Groups B, C and D, Divisions 1 and 2.
TCXP-HC-1101	Thermostat, Heat / Cool, Manual Switchover, Class I and II, Groups B, C, and D, Divisions 1 and 2.
/EH(kw)	Auxiliary Electric Heat, (specify kw), for Division 2 only. Rated Temperature Code T2A unless specified other.
/SH(MBTUH)	Auxiliary Steam Heater, (specify MBTUH), less trap or control solenoid (specify steam pressure)
/DSI	Disconnect Switch with Circuit Breaker Protection, installed
/RC	Roof Curb for Downflow Models
/LAC	Low Ambient Control, for operating at ambient temperatures between 0 and 50°F
/HGB	Hot Gas Bypass for capacity control
/CuCu	Copper fin / Copper tube condenser and evaporator coils
/CC	<b>SaveCoil 101</b> oven baked coil coating on condenser and evaporator coils
/BG	<b>BLYGOLD PoluAL</b> spray applied coil coating on condenser and evaporator coils
/EC	Full Corrosion Protection: Sheet Metal Parts Protected with Epoxy Finish; coils protected w/ <b>SaveCoil 101</b>
/ECB	Full Corrosion Protection: Sheet Metal Parts Protected with Epoxy Finish; coils protected w/ <b>BLYGOLD PoluAL</b> /
SDI	Smoke Detector, Explosion-Proof, installed with system interlock <b>DISCONTINUED NO LONGER AVAILABLE</b>
/XPM	Division 1 Motors substituted for standard motors on Division 2 units
/FAD	Manual Make-Up Air Damper

Your Representative is:



7924 Reco Avenue  
Baton Rouge, Louisiana 70814 USA  
Phone (225) 926-6950