

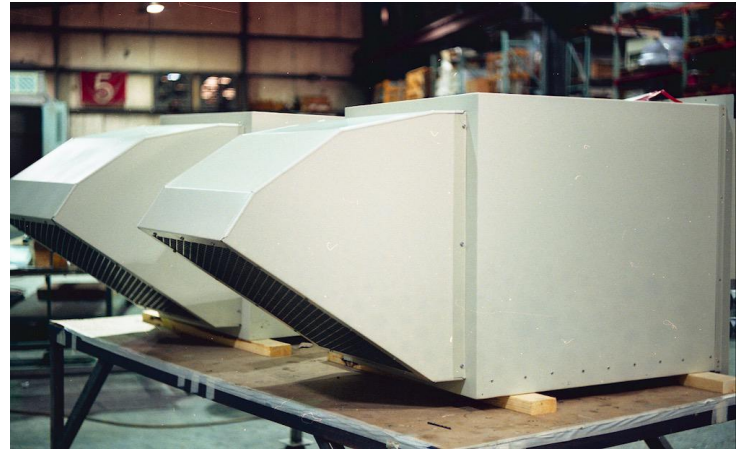

PB 10 Series **Thru-the-Wall** **Pressurization Blowers**

Listed for U. S. and Canada



Appearance may Vary with Updates and Modifications

FEATURES

- n Automatic Building Pressure Control adjustable from 0.025 to 0.20" w.c.
- n **CSA Certified** NEC Class I, Groups B*, C + D and Class II, Groups F and G for Divisions 1 and 2
- n Meet NFPA 496 and Similar Industrial Codes
- n Single or Dual (Redundant) Blower Models
- n Minimizes Heating and Cooling Requirements
- n Slide Out Chassis for Convenient Access
- n Magnehelic Gauge Pressure Indicator
- n Pressure Loss Alarm Contacts with Time Delay
- n *VariSpeed* Blowers Eliminate High Maintenance of Competitive Damper Controlled units
- n Air Filter Easily Serviced from Front Panel
- n Additional models (Series 15) available with High Dirt Loading or Deep Bed Gas-Phase Filters
- n Three-Year Limited Warranty

DESCRIPTION

PB(X) 10 Series Pressurization Blowers are the economical solution for maintaining positive room pressure. Where buildings in hazardous locations must be operated under specified positive pressure and air flow, these blowers offer a convenient means to achieve *compliance with NFPA 496*. A range of explosion proof models are CSA certified for National Electric Code Class I, Groups B^(*), C and D and Class II, Groups F and G under Divisions 1 or 2 to both U.S. and Canadian standards. Models are also available with dual blowers and automatic switch-over controls for applications that require full pressurization redundancy.

All models are pre-assembled and pretested. Included are adjustable pressure set controls, Magnehelic gage pressure readout, and start/stop controls. Pressure maintenance is fully automatic. Any previous requirement for high maintenance barometric damper controls is eliminated. Room pressure can be preset and displayed anywhere in the range of 0.025" to 0.20" w.c. . A Vari-Speed controlled pressure blower provides air flow up to 2600 cfm and continuously maintains the preset room pressure. With entrance doors closed, the air flow is precisely modulated to offset air losses from building leakage. When a door is opened, the air flow immediately increases to provide the 60 fpm minimum velocity through the opening as required by code. The available makeup air is sufficient to service rooms and buildings that have one or two access doors. Applications that require simultaneous air conditioning, higher air volumes, high external static pressures or special air filters can be met with Series PB(X) 15, PB(X) 20 or PB(X) 24 equipment.

(*) Division 2 only.

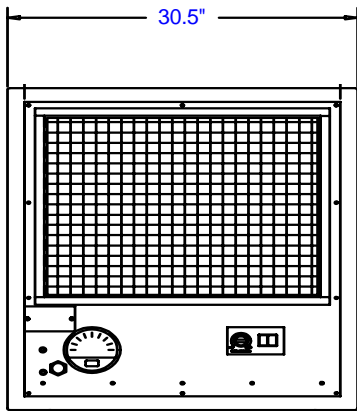
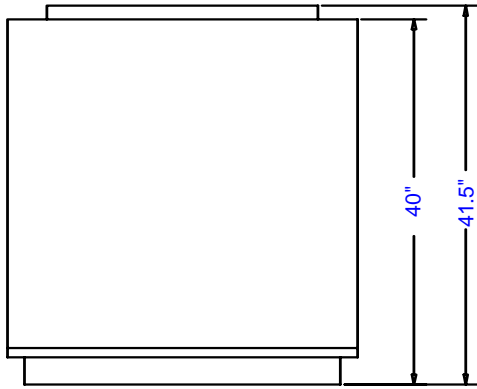

(Weight 315 lbs)

Figure 1 A:

PBX 10-2600

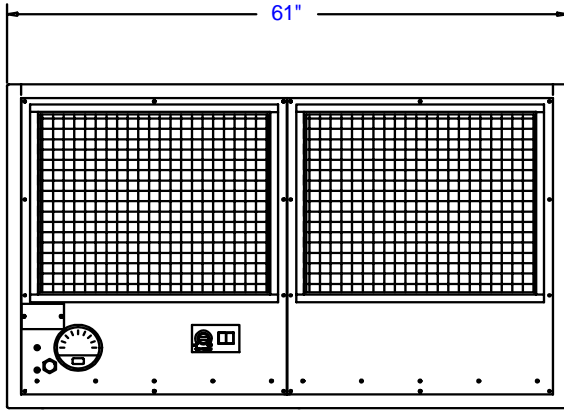
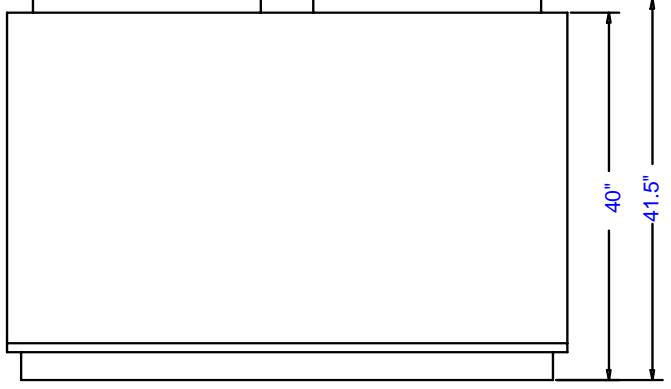

Figure 1 B: **PBX 10-2600D Redundant (Dual) Blowers**

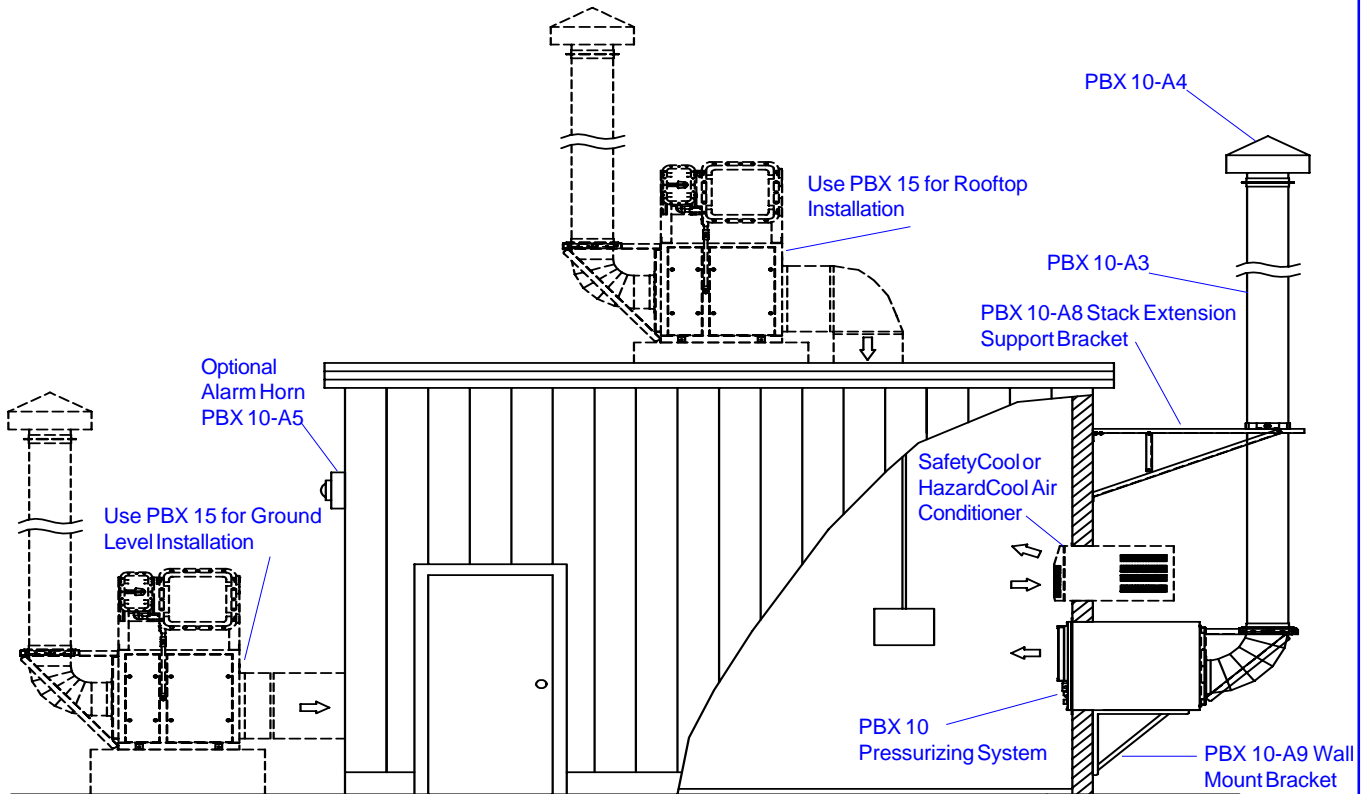
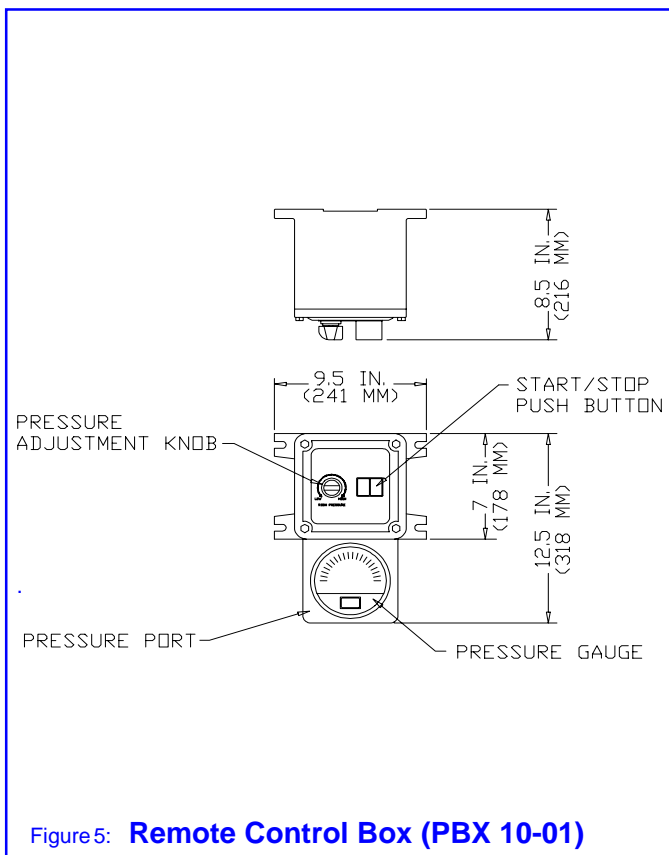
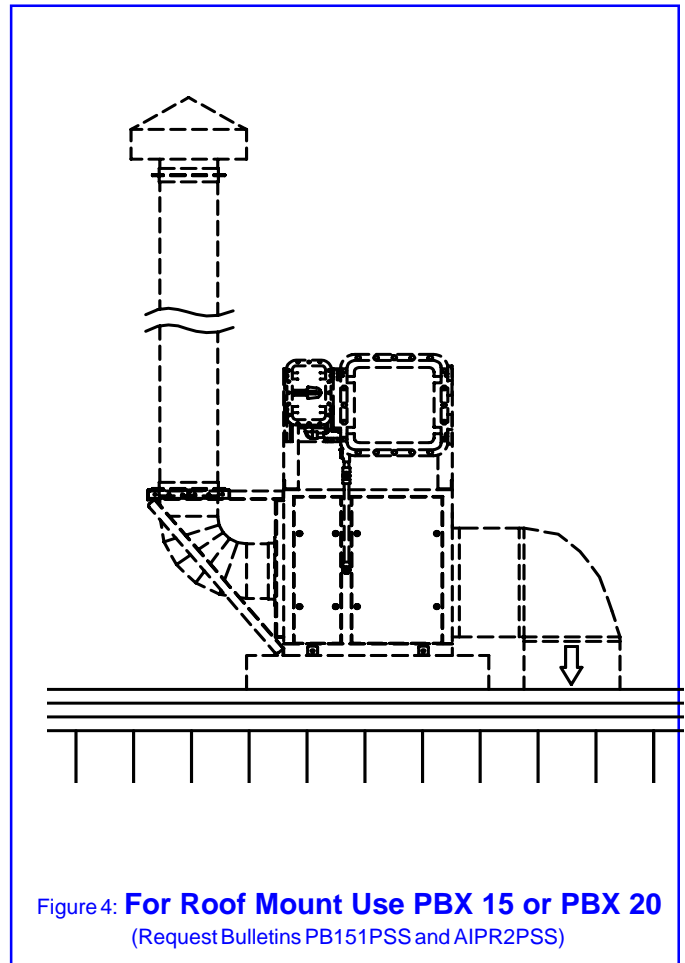
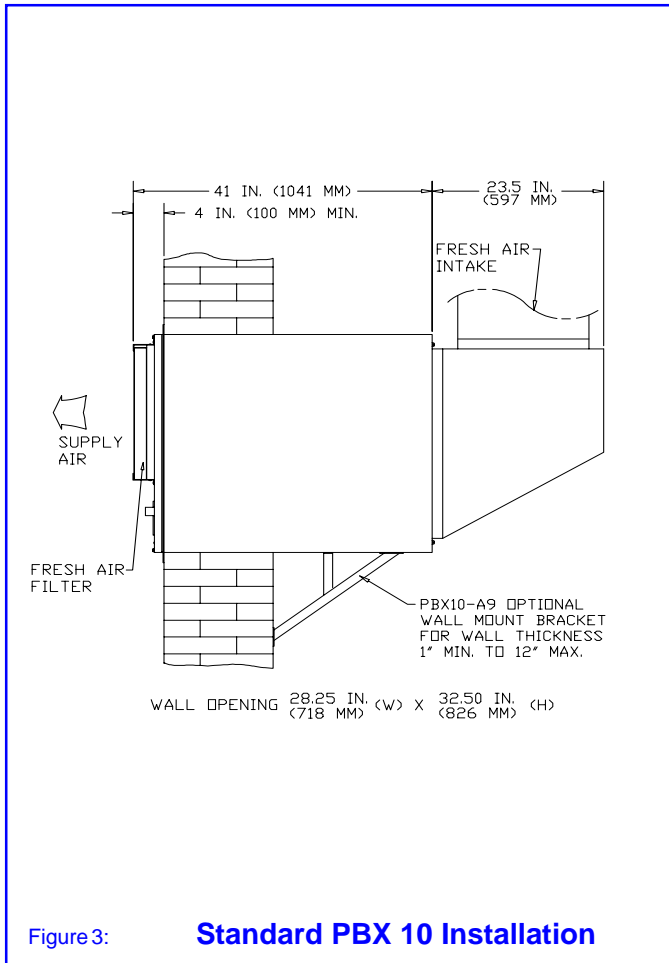

Figure 2:

Installation Options



We also Offer:

- n **Turn Key Installations** of Control and Analyzer Buildings, Panels, and Consoles
- n **Pressure Blowers** with Particulate and Gas Phase (Carbon) Filters
- n **Combined Air Conditioning / Pressurization** Systems, preassembled and pretested
- n **Explosion Proof** Air Conditioners incl. Through-the-Wall Units, Split Systems and Chillers Refrigeration and Cold Storage Systems Heaters Exhaust Blowers
- n **Testing and Certification Services** For
 - ... Building Leakage and Sealing
 - ... Classified Area Process Safety Management Programs per OSHA 29 CFR 1910.119
 - ... ISA G-1 Building Air Standards





EXPLOSION-PROOF BLOWERS

PBX 10 Series Pressurization Blowers

How to Order

1. Determine the required air flow and hazard classification, i.e. 1100 CFM and Class I, Group D, Division 2.
2. Determine the **PBX 10 Series** model number using the description shown below. For applications requiring air flow greater than 2600 CFM use Series PBX 15 or PBX 20.
3. Next select any additional options and accessories that may be required. Order these items separately.
4. For technical or sales information call your local representative or our Technical Service at (800) 654-3857.

Model Number Description

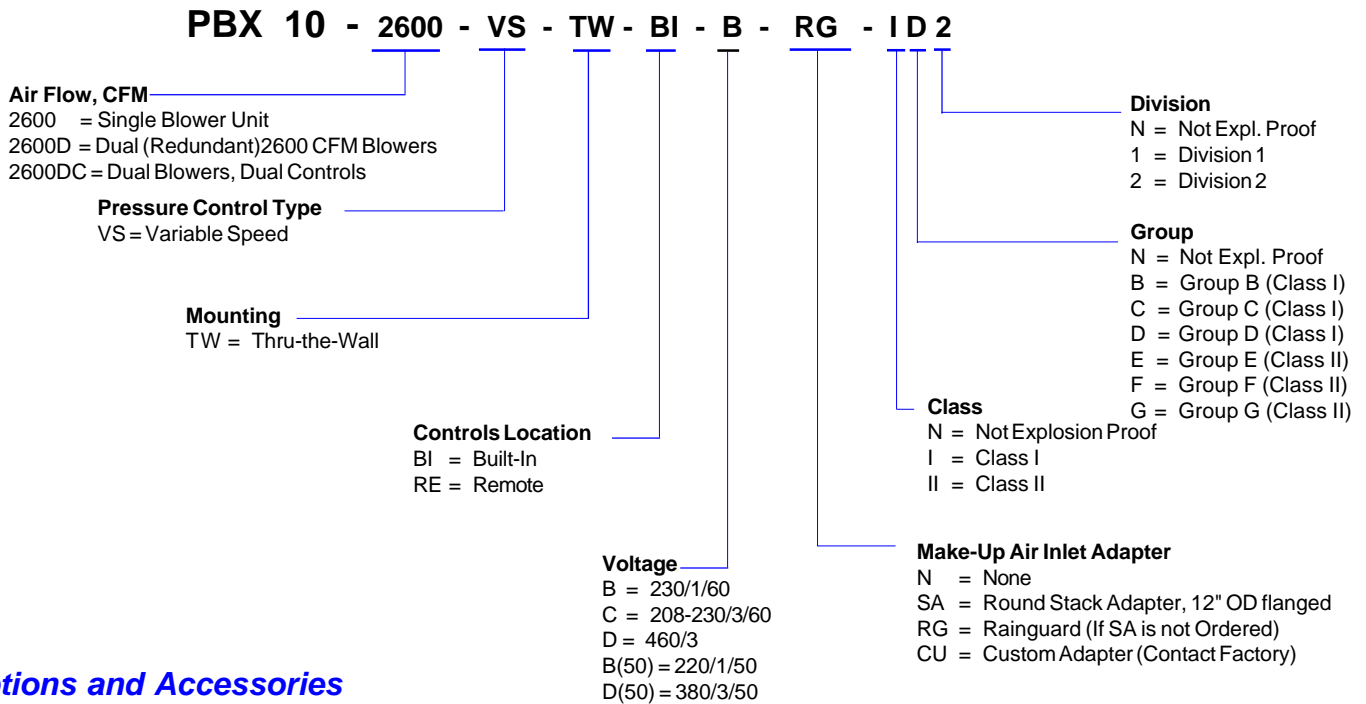

Options and Accessories

Model	Description	Price
PBX 10-A2	Filters, Replacement, Box of 12	
PBX 10-A3(12")	Make-Up Air Duct Section, 12" O.D x 10', with hardware; requires PBX 10-A4	
PBX 10-A4	Make-Up Air Duct Top Section, 12" O.D., including rain cap, bird screen, and hardware	
PBX 10-A5	Pressure Loss Alarm Horn, Expl. Proof, delay adjustable 2-12 min; with Acknowledgement Button	
PBX 10-A6	Automatic Purge Control, with time adjustable delay before contact closure	
PBX 10-A8	Air Intake Stack Extension Support Bracket. (See Figure 2)	
PBX 10-A9	Wall Mounting Brackets, Stainless Steel, for supporting thru-the-wall units. (See Figure 2)	
PBX 10-11	Housing and all Exposed Metal Parts Corrosion Protected with Epoxy Paint	
PBX 10-12	Ranguard (-RG), for protecting Make-Up Air Inlet when Make-Up Air Duct is not installed	
PBX 10-EXP	Export Crate, heavy duty, for marine shipment and rough handling, approx. 360 lbs, 65 cu-ft	(*)

(*) = For air shipment crates weigh approximately 100 lbs. less. If PBX 10-A4 and A5 are ordered add \$ _____ for second crate.

Your Representative is:



SCIENTIFIC SYSTEMS CORPORATION
A Member of Marduk Holding Corp.
7924 Reco Avenue
Baton Rouge, Louisiana 70814 USA
Phone (225) 926-6950
Toll Free (800) 654-3857
FAX (225) 926-6973