

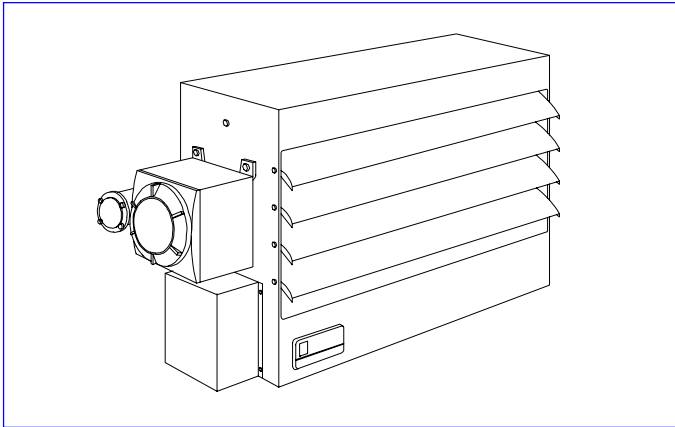

# Heaters and Controls for Hazardous Locations



## Liquid-to-Air Forced Air Heaters

- UL and CSA listed for NEC Class I, Groups C <sup>(1)</sup>, D and Class II, Groups E, F and G, Divisions 1 and 2
- Capacities from 3 to 35 kw
- Permanently Sealed Heater Coil Assembly
- Epoxy Coated 14 ga steel Cabinet
- Adjustable Louvers for Directional Air Control
- Thermally Protected Explosion Proof Motor
- Easily Accessible Terminal Enclosure
- Built-In Explosion Proof Thermostat<sup>(o)</sup>

o = optional

### LIQUID-TO-AIR, FORCED AIR (LF) HEATERS for CEILING or WALL (CW) INSTALLATION

MODEL <sup>(1)</sup> EHXP-	IDENT. NO.	KW	BTUH	°F RISE	VAC/PH <sup>(3)</sup>	AMPS	HEIGHT <sup>(2)</sup>	WIDTH <sup>(2)</sup>	DEPTH <sup>(2)</sup>	WT
				°F			INCHES	INCHES	INCHES	SHIP LBS
1024LF-208/1-CW-ID1-T3B	T3B	3.0	10,250	19	208/1	15.3	18-1/2	24-1/2	23	151
1024LF-208/3-CW-ID1-T3B	T3B	3.0	10,250	19	208/3	8.9	18-1/2	24-1/2	23	151
1024LF-240/1-CW-ID1-T3B	T3B	3.0	10,250	19	240/1	13.5	18-1/2	24-1/2	23	151
1024LF-240/3-CW-ID1-T3B	T3B	3.0	10,250	19	240/3	7.9	18-1/2	24-1/2	23	151
1024LF-480/3-CW-ID1-T3B	T3B	3.0	10,250	19	480/3	3.9	18-1/2	24-1/2	23	151
1707LF-208/3-CW-ID1-T3B	T3B	5.0	17,050	31.6	208/3	14.4	18-1/2	24-1/2	23	151
1707LF-240/3-CW-ID1-T3B	T3B	5.0	17,050	31.6	240/3	12.7	18-1/2	24-1/2	23	151
1707LF-480/3-CW-ID1-T3B	T3B	5.0	17,050	31.6	480/3	6.4	18-1/1	24-1/2	23	151
2561LF-208/3-CW-ID1-T3B	T3B	7.5	25,600	27.9	208/3	21.4	18-1/2	24-1/2	23	151
2561LF-240/3-CW-ID1-T3B	T3B	7.5	25,600	27.9	240/3	18.7	18-1/2	24-1/2	23	151
2561LF-480/3-CW-ID1-T3B	T3B	7.5	25,600	27.9	480/3	9.4	18-1/2	24-1/2	23	151
3415LF-208/3-CW-ID1-T3B	T3B	10.0	34,100	37.2	208/3	28.3	18-1/2	24-1/2	23	151
3415LF-240/3-CW-ID1-T3B	T3B	10.0	34,100	37.2	240/3	24.7	18-1/2	24-1/2	23	151
3415LF-480/3-CW-ID1-T3B	T3B	10.0	34,100	37.2	480/3	12.4	18-1/2	24-1/2	23	151
5122LF-208/3-CW-ID1-T3B	T3B	15.0	51,200	27.1	208/3	41.4	22-1/2	28-1/2	23	173
5122LF-240/3-CW-ID1-T3B	T3B	15.0	51,200	27.1	240/3	36.0	22-1/2	28-1/2	23	173
5122LF-480/3-CW-ID1-T3B	T3B	15.0	51,200	27.1	480/3	18.0	22-1/2	28-1/2	23	173
6830LF-480/3-CW-ID1-T3B	T3B	20.0	68,250	36.1	480/3	24.0	22-1/2	28-1/2	23	173
8537LF-480/3-CW-ID1-T3B	T3B	25.0	85,300	21.9	480/3	30.1	26-1/2	32-1/2	23	204
10235LF-480/3-CW-ID1-T3B	T3B	30.0	102,350	26.3	480/3	36.1	26-1/2	32-1/2	23	204
11945LF-480/3-CW-ID1-T3B	T3B	35.0	119,450	28.0	480/3	42.1	26-1/2	32-1/2	23	204

(1) Basic models are UL and CSA listed for hazardous locations classified Class I, Group D and Class II, Groups E, F, and G for Divisions 1 and 2. If Group C is required, substitute "IC1" for "ID1" in the order code and add \_\_\_\_\_% to the price.

(2) Dimensions and performance data are subject to change. Certified dimensions available at time of order.

(3) Also available in 50 Hertz models. Contact factory for 50 Hz model numbers.

### ACCESSORIES AND OPTIONS

/TIN	Thermostat installed on heater .....
EHXP-MBC-01	Wall Mounting Kit, for bolting to substantial building walls, approx. 25 lbs .....
EHXP-MBC-02	Hanging Mounting Kit, requires 1/2" pipe, cut and threaded (not supplied), approx. 5 lbs .....
EHXP-MBC-03	Pipe Mounting Kit, for attaching to 3-1/2" Schedule 40 pipe (pipe not supplied), approx. 25 lbs .....
EXHP-MBC-04	Basic Mounting Kit, for applications where support arm can be bolted or welded directly to structural steel or concrete, approx. 20 lbs .....