



AIR CONDITIONERS, Severe Duty

VA 40 Series Vertical Air Conditioners

How to Order

- 1.- Determine required cooling capacity in nominal tons (12,000 BTUH per ton). For computer assisted load calculations contact factory and request Technical Support Bulletin REHV1FRM.
- 2.- Determine required voltage configuration. Models are available for 50 or 60 Hertz.
- 3.- For 'explosion proof' models determine hazard classification per National Electric Code. For example: Class I, Group D, Division 2. For models with combined pressurization and air conditioning request bulletin AIPR3PSS.
- 4.- Determine if supply air discharge shall be upward or horizontal. Return air opening is always in the same location.
- 5.- Select the model number by following the order code below.
- 6.- Then select the desired Accessories and Options. Add a slash (/) and the code for each selected item to the end of the model number. For example: **VA 40 - H - 05.0 - 1 - B - ID2 / EH(4) / FDI**

Model Number Description

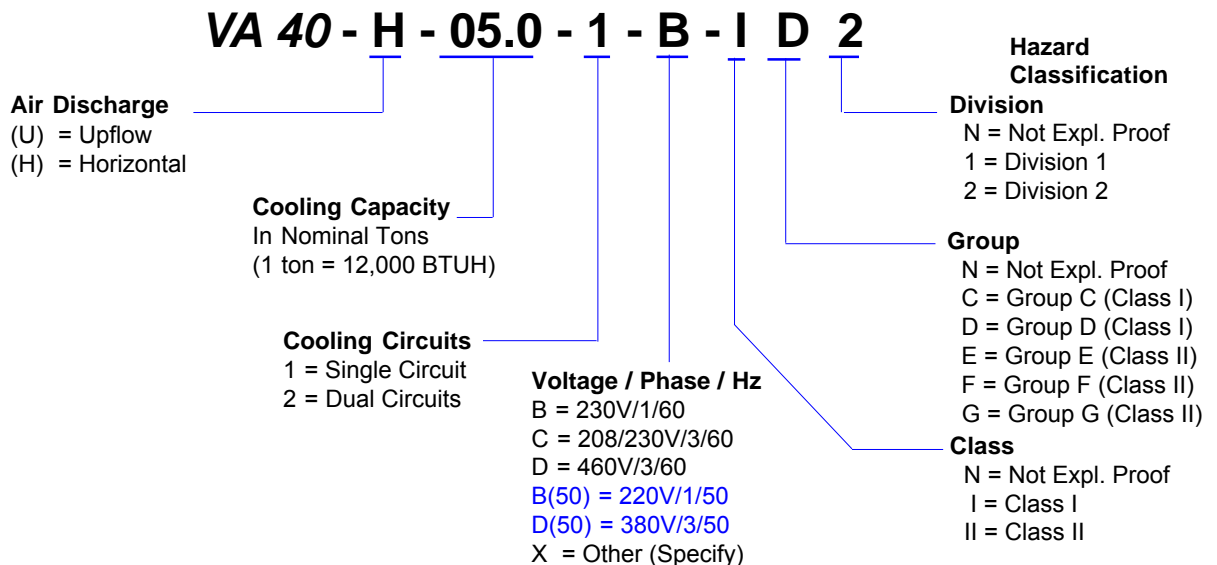

Accessories and Options

Model No	Description
/ SS	Stainless Steel Housing, 14 ga Type 316 with 16 ga access panels, includes option "/ EC"
TCXP-C-1101	Thermostat, "Cool" or "Fan Only", Class I and II, Groups B, C and D, Divisions 1 and 2
TCXP-HC-1101	Thermostat, "Heat", "Cool" or "Fan Only"; Manual Switchover, Cl. I and II, Grps. B, C, and D, Div. 1 and 2
/ EH(kw)	Auxiliary Electric Heat (*), (specify kw)
/ SH(MBtuh)	Auxiliary Steam Heater, less trap or control solenoid, (specify MBtuh and supply pressure)
/ FDI	Disconnect Switch with Circuit Breaker Protection, installed
/ DSI	Disconnect Switch, non-fused, installed
/ LAC	Low Ambient Control, for operating at ambient temperatures between 0 and 50 °F
/ HGB	Hot Gas Bypass for capacity control
/ CC	SaveCoil 101 oven baked coil coating on condenser and evaporator coils
/ EC	Full Corrosion Protection: Non stainless metal parts epoxy coated; Coils are SaveCoil 101 protected
/ SDI	Smoke Detector, installed with system interlock
/ FAD	Manual Make-Up Air Damper
/ Cu-Cu	Copper coils and fins in lieu of copper coils w/ aluminum fins. End plates galvanized unless otherwise specied.
/ MAC	Make-Up Air Inlet Rain Cap
/ EXP	Export Crate, heavy duty, for rough handling and marine shipment

(*) Explosion proof heaters rated Temp Code T2A unless otherwise specified. Electric heaters for Div. 1 are field installed discharge air duct.