



ICEWAGON CHILLERS

EXPLOSION PROOF AND NON-Classified ICEWAGON CHILLERS

How to Order

- 1.- Determine the preferred medium of cooling, Air or Water.
 - 2.- Determine required cooling capacity in nominal tons (12,000 BTUH per ton). For computer assisted load calculation contact factory and request Technical Support Bulletin REHV1FRM.
 - 3.- Determine required voltage configuration. For 50 Hertz models contact factory.
 - 4.- Determine hazard classification per National Electric Code (NEC). For example Class I, Group D, Division 2..
 - 4.- Select the model number following the order code below.
 - 5.- Scan the "Options and Accessories" listing below and select the desired items. Order by adding and dash and the order code of the selection accessory or option. For example: **DS-300(3)-AC-D-ICD2**.
- For technical or pricing information contact your representative or Sales Engineering at (225)-926-6950.

Model Number Description

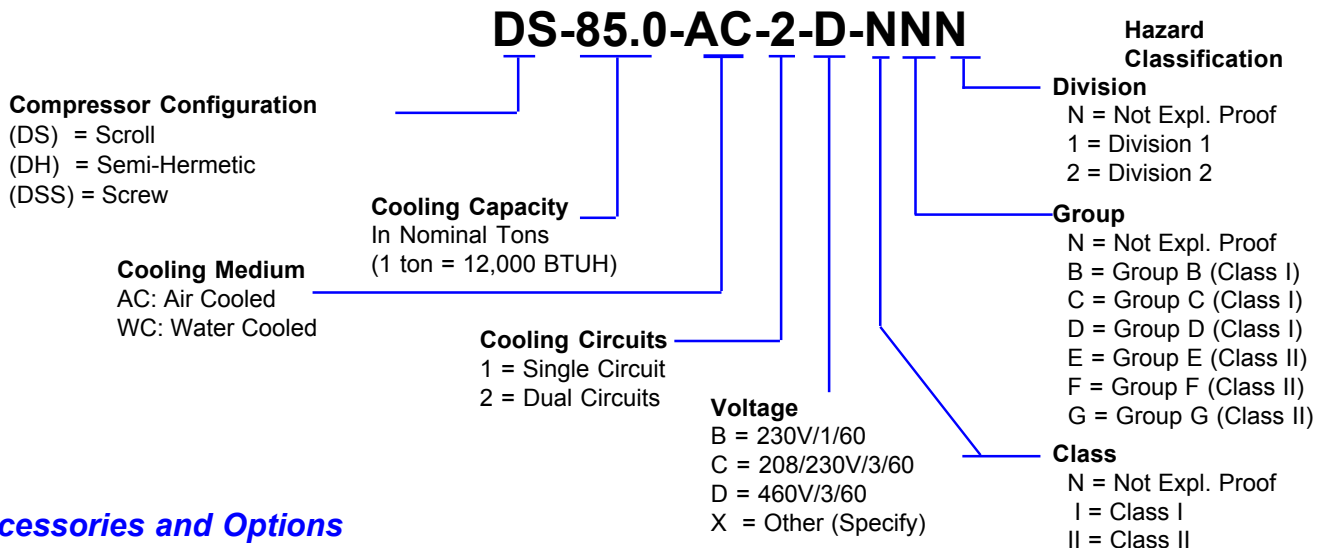

Accessories and Options

Model	Description
/ TH(kw)	Auxiliary Electric Heat, (specify kw), for Division 2 only. Rated Temperature Code T2A unless specified other.
/ SH(MBTUH)	Auxiliary Steam Heater, (specify MBTUH), less trap or control solenoid (specify steam pressure)
/ DSI	Disconnect Switch with Circuit Breaker Protection, installed
/ RMC	Roof Curb for Outdoor Models
/RC	Remote Controls [usually for IBCD2 Models]
/ LAC	Low Ambient Control, for operating at ambient temperatures between 0 and 50°F
/HA	High Ambient Design [140°F Condensing]
/ HGB	Hot Gas Bypass for capacity control
/ CuCu	Copper fin / Copper tube condenser and evaporator coils
/ CC	SaveCoil 101 oven baked coil coating on condenser and evaporator coils
/BG	BLYGOLD PoluAL spray applied coil coating on condenser and evaporator coils
/ EC	Full Corrosion Protection: Sheet Metal Parts Protected with Epoxy Finish; coils protected w/ SaveCoil 101
/ ECB	Full Corrosion Protection: Sheet Metal Parts Protected with Epoxy Finish; coils protected w/ BLYGOLD PoluAL
/SH	Full Stainless Steel Package for corrosion resistance
/RED	Total System Redunancy
/DP	Dual Pumps

Your Representative is:



GCI

REFRIGERATION
TECHNOLOGIES, INC

7924 Reco Avenue
Baton Rouge, Louisiana 70814 USA
Phone (225) 926-6950